

Plumbing



Pacemaker Ruudglas Energy Miser® Electric Water Heater



**Get
4 MORE YEARS
with ProtectionPlus™**

Available in 30, 40, 50, 65, 80 and 120 Gallon Tall – 30 and 50 Gallon Medium – 20, 30, 38 and 47 Gallon Short Models

- ▶ 6-Year Limited Tank and Parts Warranty*
- ▶ With ProtectionPlus™ the 6-Year Limited Tank Warranty Becomes 10 Years!

- EverKleen™ self cleaning device
- Brass drain valve
- Temperature and pressure relief valve included
- Isolated tank design reduces conductive heat loss
- High efficiency resistored heating elements
- Anode rod equalizes aggressive water action
- Electric junction box located above heating elements for easy installation
- Over-temperature protector cuts off power in excess temperature situations
- Automatic thermostat keeps water at desired temperature
- Meets or exceeds requirements of the National Appliance Energy Conservation Act (NAECA)

HE HIGH EFFICIENCY MODELS FEATURE:

- High performance and lower operating cost
- Compliant with many electric utility incentive programs

*See Residential Warranty Information Brochure for complete warranty information.

Energy Factor and Average Annual Operating Costs based on D.O.E. (Department of Energy) test procedures. D.O.E. national average fuel rate electricity 8.6¢/KWH.



DESCRIPTION			FEATURES		ROUGHING IN DIMENSIONS (SHOWN IN INCHES)				ENERGY INFORMATION	
T Y P E	GAL. CAP.	MODEL NUMBER	FIRST HOUR RATING G.P.H.	RECOVERY IN G.P.H. @ 90° RISE	TANK HEIGHT A	HEIGHT TO WATER CONN. B	DIAMETER C	APPROX. SHIP WT. (LBS.)	ENERGY FACTOR	AVERAGE ANNUAL OPER. COST
T A L L	40	PE3R-40-2	55	21	46-3/4	46-3/4	22-1/4	104	0.94	\$402
	50	PE3R-52-2	67	21	57	57	22-1/4	123	0.94	\$402
	65	PE3R-66-2	71	21	58-3/4	58-3/4	23	160	0.91	\$415
	80	PE3R-80-2	88	21	59	59	24-1/2	181	0.91	\$415
MED.	50	PE3MR-52-2	63	21	46	46	24-1/4	128	0.93	\$406
T A L L	30	PE2-30-2	46	21	45-3/4	45-3/4	17-3/4	80	0.93	\$406
	40	PE2-40-2	53	21	46-1/2	46-1/2	19-3/4	95	0.92	\$411
	40	PE2H-40-2	53	21	59-1/4	59-1/4	17-3/4	96	0.92	\$411
	50	PE2-52-2	61	21	57	57	19	107	0.91	\$415
	65	PE2-66-2	70	21	58-1/2	58-1/2	21	150	0.89	\$425
	80	PE2-80-2	88	21	59	59	23	177	0.86	\$439
	120	PE2-120-2	100	21	62-1/2	62-1/2	28-1/4	324	0.85	\$444
MED.	30	PE2M-30-2	40	21	36	36	19-3/4	80	0.93	\$406
	50	PE2M-52-2	63	21	46	46	21-3/4	117	0.90	\$420
S H O R T	20	PE2S-20-2	-	21	31-1/2	31-1/2	17	62	N/A	N/A
	30	PE2S-30-2	41	21	30	30	22-1/4	83	0.93	\$406
	38	PE2S-40-2	47	21	31-1/2	31-1/2	23	108	0.92	\$411
	47	PE2S-50-2	55	21	32	32	26-1/4	149	0.91	\$415

- Heaters furnished with standard 240 volt AC, single phase non-simultaneous wiring, and 4500 watt upper and lower heating elements.
- If heating elements of different wattages than those shown are demanded by zone requirements, they must be specifically requested.
- Single element models available on special order (6000W max.). Substitute "1" for "2" in model number.
- Special Wiring Options – A limited number of special wiring options are available. Consult factory for price and availability.
- All models equipped with heat traps.

Recovery = wattage/2.42 x temp. rise °F.
Example: $\frac{4500W}{2.42 \times 90^\circ} = 21 \text{ GPH}$

These units are designed to meet or exceed ANSI (American National Standards Institute) requirements and have been tested according to D.O.E. test procedures and meet or exceed the energy efficiency requirements of NAECA, ASHRAE standard 90, ICC Code and all state energy efficiency performance criteria for energy consuming appliances.

Before purchasing this appliance, read important energy cost and efficiency information available from your supplier.



For more details, see form 101-7.

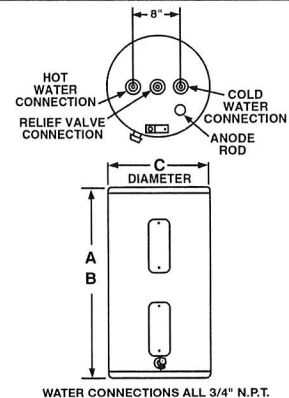

WATER CONNECTIONS ALL 3/4" N.P.T.

In keeping with its policy of continuous progress and product improvement, Ruud reserves the right to make changes without notice.

Ruud Water Heaters • 101 Bell Road, Montgomery, Alabama 36117-4305 • www.ruud.com



Residential Electric Water Heater **USE & CARE MANUAL**



WITH INSTALLATION INSTRUCTIONS FOR THE CONTRACTOR

Single and Double Element Models 20 - 120 Gallon Capacity

The purpose of this manual is twofold: one, for the installing contractor, to provide requirements and recommendations for the proper installation and adjustment of the water heater; and two, for the owner-operator, to explain the features, operation, safety precautions, maintenance and trouble shooting of the water heater. This manual also includes a parts list.

It is imperative that all persons who are expected to install, operate or adjust this water heater read the instructions carefully so that they may understand how to do so.

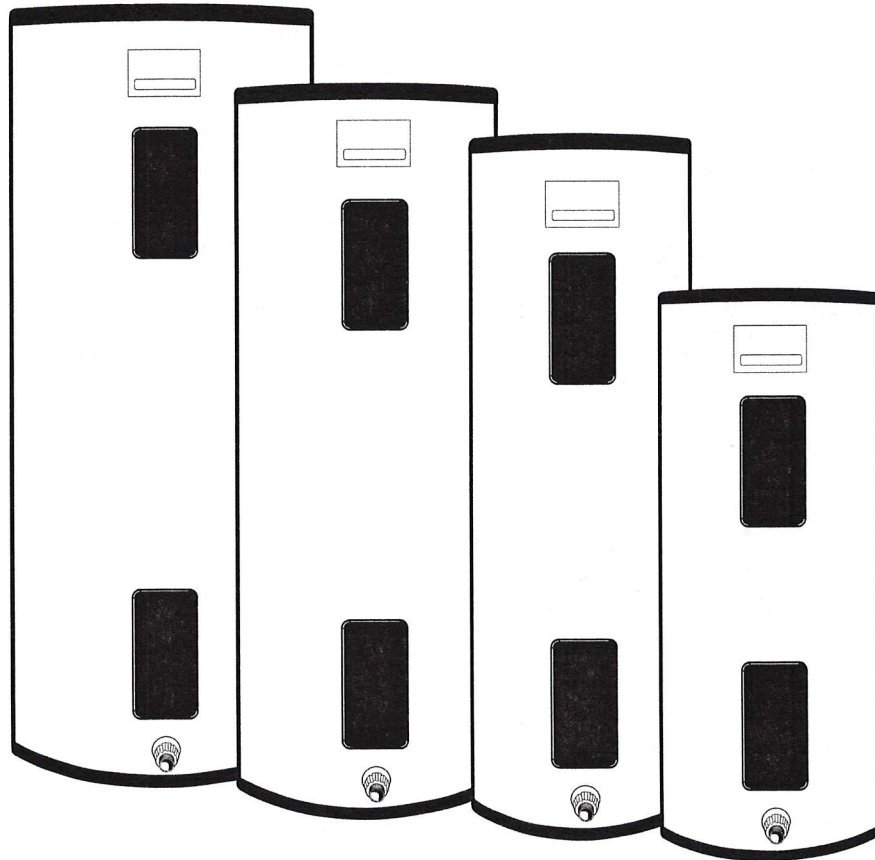

 Do Not Destroy this Manual. Please read carefully and keep in a safe place for Future Reference.

 Recognize this symbol as an Indication of Important Safety Information!

 **PROPOSITION 65:** This appliance contains fiberglass insulation. Respirable particles of fiberglass are known to the State of California to cause cancer.

! General Safety Precautions

Be sure to read and understand the entire Use & Care Manual before attempting to install or operate this water heater. It may save you time and cost. Pay particular attention to the General Safety Precautions. Failure to follow these warnings could result in serious bodily injury or death. Should you have problems understanding the instructions in this manual, or have any questions, STOP, and get help from a qualified installer, service technician, or the local electric utility.

! WARNING

Gasoline, as well as other flammable materials and liquids (adhesives, solvents, etc.), and the vapors they produce, are extremely dangerous. DO NOT handle, use or store gasoline or other flammable or combustible materials anywhere near or in the vicinity of a water heater. The arc drawn in the water heater controls can ignite these vapors. Failure to do so can result in property damage, bodily injury, or death.

WATER TEMPERATURE ADJUSTMENT - Safety and energy conservation are factors to be considered when selecting the water temperature setting of water heater's thermostat. Water temperatures above 125°F can cause severe burns or death from scalding. Be sure to read and follow the warnings outlined on the label pictured below. This label is also located on the water heater near the thermostat access panel

! DANGER

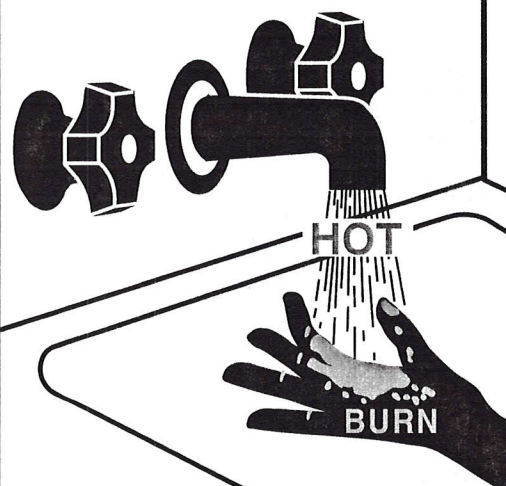

Water temperature over 125°F can cause severe burns instantly or death from scalds.

Children, disabled and elderly are at highest risk of being scalded.

See instruction manual before setting temperature at water heater.

Feel water before bathing or showering.

Temperature limiting valves are available, see manual.

TIME / TEMPERATURE RELATIONSHIPS IN SCALDS

Temperature	Time to Produce Serious Burn
120° F	More than 5 minutes
125° F	1 1/2 to 2 minutes
130° F	About 30 seconds
135° F	About 10 Seconds
140° F	Less than 5 seconds
145° F	Less than 3 seconds
150° F	About 1 1/2 seconds
155° F	About 1 second

Table courtesy of Shriners Burn Institute

The chart shown above may be used as a guide in determining the proper water temperature for your home.

NOTE: Households with small children, disabled, or elderly persons may require a 120°F or lower thermostat setting to prevent contact with "HOT" water.

The temperature of the water in the heater is regulated by the adjustable surface mounted thermostat(s) located behind the Jacket Access Panel(s). Dual element heaters have two thermostats. To comply with safety regulations the thermostat(s) were set at 120° F before the water heater was shipped from the factory.

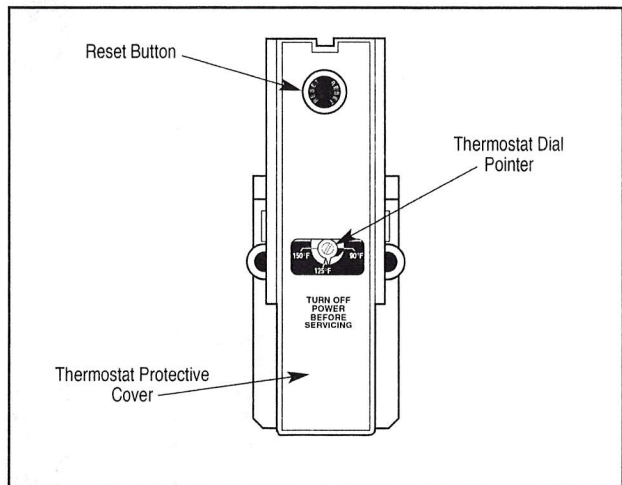

The illustration above shows the temperature adjustment dial used for setting the water temperature. Refer to Operation section of this manual for detailed instructions in how to adjust the thermostat(s).

! DANGER

There is a Hot Water SCALD Potential if the thermostat is set too high.

Mixing valves for reducing point of use water temperature by mixing hot and cold water in branch water lines are available. Contact a licensed plumber or the local plumbing authority for further information.

Introduction

The location chosen for the water heater must take into consideration the following:

LOCAL INSTALLATION REGULATIONS

This water heater must be installed in accordance with these instructions, local codes, utility company requirements or, in the absence of local codes, the latest edition of the National Electrical Code. It is available from some local libraries or can be purchased from the National Fire Prevention Association, Batterymarch Park, Quincy, MA 02269 as booklet ANSI/NFPA 70.

LOCATION

Locate the water heater in a clean dry area as near as practical to the area of greatest heated water demand. Long uninsulated hot water lines can waste energy and water. Place the water heater in such a manner that the thermostat and element access panels can be removed to permit inspection and servicing such as removal of elements or checking controls. The water heater and water lines should be protected from freezing temperatures. Do not install the water heater in outdoor, unprotected areas.

CAUTION

The water heater should not be located in an area where leakage of the tank or connections will result in damage to the area adjacent to it or to lower floors of the structure. Where such areas cannot be avoided, it is recommended that a suitable catch pan, adequately drained, be installed under the water heater.

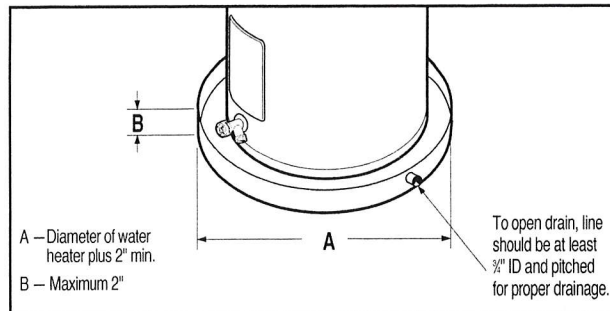

Figure 1. — Auxiliary Catch Pan

NOTE: Auxiliary catch pan installation MUST conform to local codes.

Catch Pan Kits are available from the distributor or store where the water heater was purchased

WARNING

This water heater SHOULD NOT be installed in a space where liquids which give off flammable vapors are to be used or stored. Such liquids include gasoline, LP gas (butane and propane), paint or adhesives and their thinners, solvents or removers. Because of natural air movement in a room or other enclosed space, flammable vapors can be carried from where their liquids are being used or stored. The arc drawn within the water heater's control can ignite these vapors causing an explosion or fire which may result in severe burns or death to those in range, as well as property damage.

Installation

- 1. INSPECT SHIPMENT** — Inspect water heater for possible damage. Check the markings on the rating plate of the water heater to be certain the power supply corresponds to that for which the water heater is equipped.
- 2. THERMAL EXPANSION** — Determine if a check valve exists in the inlet water line. It may have been installed in the cold water line as a separate back flow preventer, or it may be part of a pressure reducing valve, water meter or water softener. A check valve located in the cold water inlet line can cause what is referred to as a "closed water system". A cold water inlet line with no check valve or back flow prevention device is referred to as an "open" water system.

As water is heated, it expands in volume and creates an increase in the pressure within the water system. This action is referred to as "thermal expansion". In an "open" water system, expanding water which exceeds the capacity of the water heater flows back into the city main where the pressure is easily dissipated.

A "closed water system", however, prevents the expanding water from flowing back into the main supply line, and the result of "thermal expansion" can create a rapid, and dangerous pressure increase in the water heater and system piping. This rapid pressure increase can quickly reach the safety setting of the relief valve, causing it to operate during each heating cycle. Thermal expansion, and the resulting rapid, and repeated expansion and contraction of components in the water heater and piping system can cause premature failure of the relief valve, and possibly the heater itself. Replacing the relief valve **will not** correct the problem!

The suggested method of controlling thermal expansion is to install an expansion tank in the cold water line between the water heater and

the check valve. (refer to Figure 2.) The expansion tank is designed with an air cushion built in that compresses as the system pressure increases, thereby relieving the over pressure condition and eliminating the repeated operation of the relief valve. Other methods of controlling thermal expansion are also available. Contact your installing contractor, water supplier, or plumbing inspector for additional information regarding this subject.

- 3. WATER SUPPLY CONNECTIONS** — Refer to Fig. 2 for suggested typical installation. The installation of unions or flexible copper connectors is recommended on the hot and cold water connections so that the water heater may be easily disconnected for servicing if necessary. The HOT and COLD water connections are clearly marked and are 3/4" NPT on all models. Install a shut-off valve in the cold water line near the water heater.

IMPORTANT!! Do not apply heat to the hot or cold water connections. If sweat connections are used, sweat tubing to adapter before fitting adapter to hot or cold water connections on heater. Any heat applied to the hot or cold water supply fittings will permanently damage them.

- 4. RELIEF VALVE** — A new combination temperature and pressure relief valve, complying with the Standard for Relief Valves and Automatic Gas Shutoff Devices for Hot Water Supply Systems, ANSI Z21.22, must be installed in the opening provided and marked for the purpose on the water heater. (Refer to Fig. 2.) No valve of any type should be installed between the relief valve and the tank. Local codes shall govern the installation of relief valves.

The pressure rating of the relief valve must not exceed 150 PSI, the maximum working pressure of the water heater as marked on the rating plate. The BTUH Rating of the relief valve must not be less than the input rating of the water heater as indicated on the

Installation

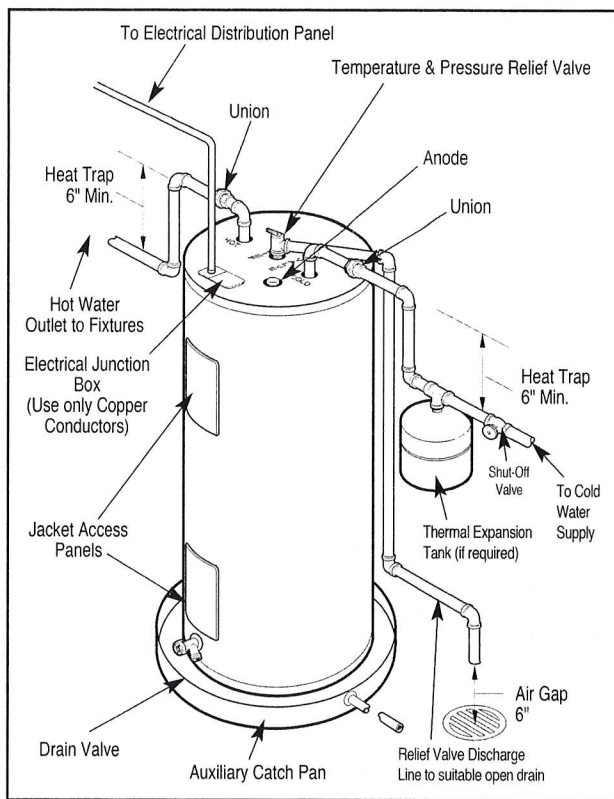

Figure 2. — Typical Installation

rating label located on front of the heater (1 watt = 3.412 BTUH). Connect the outlet of the relief valve to a suitable open drain so that the discharge water cannot contact live electrical parts and to eliminate potential water damage. Piping used should be of a type approved for hot water distribution. The discharge line must be no smaller than the outlet of the valve and must pitch downward from the valve to allow complete drainage (by gravity) of the relief valve and discharge line. The end of the discharge line should not be threaded or concealed and should be protected from freezing. No valve of any type, restriction or reducer coupling should be installed in the discharge line.

- 5. TO FILL WATER HEATER** — Make certain drain valve is completely closed. Open shut-off valve in cold water supply line. Open each hot water faucet slowly to allow air to vent from the water heater and piping. A steady flow of water from the hot water faucet(s) indicates a full water heater.

⚠ WARNING

Tank **MUST BE** full of water before power is turned on. Heating element(s) **WILL BE DAMAGED** if energized for even a short time while tank is dry. The water heater's warranty does not cover damage or failure resulting from operation with an empty or partially empty tank. (Reference is made to the limited warranty for complete terms and conditions.)

- 6. ELECTRICAL CONNECTIONS** — A separate branch circuit with copper conductors, overcurrent protective device and suitable disconnecting means must be provided by a qualified electrician. All wiring must conform to local codes or latest edition of the National Electrical Code ANSI/NFPA 70.

The water heater is completely wired to the junction box inside jacket at top front of water heater. An opening for 1/2" or 3/4" electrical fitting is provided for field wiring connections. (Refer to Fig. 3)

The voltage requirements and wattage load for the water heater is specified on the rating plate on front of heater.

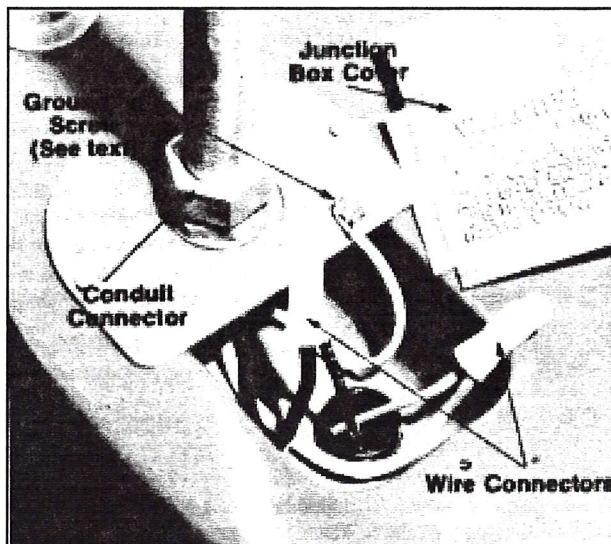

Figure 3. — Water Heater Junction Box.

Table 1 recommends minimum branch circuit sizing based on National Electric Code. Refer to wiring diagram on back cover of this manual for field wiring connections.

Total Water Heater Wattage	Phase	Recommended Over Current Protection (Fuse or Circuit Breaker) Amperage Rating				Copper Wire Size - AWG Based on N.E.C. Table 310-16 (75°C.)			
		208V	240V	277V	480V	208V	240V	277V	480V
3,000	1	20	20	15	15	12	12	14	14
	3	20	20	---	15	12	12	---	14
4,000	1	25	25	20	15	10	10	12	14
	3	25	25	---	15	10	10	---	14
4,500	1	30	25	25	15	10	10	10	14
	3	30	25	---	15	10	10	---	14
5,000	1	30	30	25	15	10	10	10	14
	3	30	30	---	15	10	10	---	14
5,500	1	35	30	25	15	8	10	10	14
	3	35	30	---	15	8	10	---	14
6,000	1	40	35	30	20	8	8	10	12
	3	35	30	---	15	8	10	---	14
8,000	1	50	45	40	25	8	8	8	10
	3	45	40	---	20	8	8	---	12
9,000	1	---	50	45	25	---	8	8	10
	3	50	45	---	25	8	8	---	10
10,000	1	---	---	50	30	---	---	8	10
	3	---	50	---	25	---	8	---	10
11,000	1	---	---	50	30	---	---	8	10
	3	---	50	---	25	---	8	---	10
12,000	1	---	---	---	35	---	---	---	8
	3	---	---	---	30	---	---	---	10

Table 1. — Branch Circuit Sizing Guide Based on N.E.C. ANSI / NFPA 70

Installation

⚠ CAUTION

The presence of water in the piping and water heater does not provide sufficient conduction for a ground. Non-metallic piping, dielectric unions, flexible connectors etc. can cause the water heater to be electrically isolated.

The branch circuit wiring should include either:

- A. Metallic conduit or metallic sheathed cable approved for use as a grounding conductor and installed with fittings approved for the purpose.
- B. Non-metallic sheathed cable or metallic conduit or metallic sheathed cable not approved for use as a ground conductor shall include a separate conductor for grounding. It should be attached to the ground terminals of the water heater and the electrical distribution box. (Refer to Fig. 3)

⚠ CAUTION

The manufacturer's warranty does not cover any damage or defect caused by installation, attachment or use of any type of energy saving or other unapproved devices (other than those authorized by the

manufacturer) into, onto or in conjunction with the water heater. The use of unauthorized energy saving devices may shorten the life of the water heater and may endanger life and property. The manufacturer disclaims any responsibility for such loss or injury resulting from the use of such unauthorized devices.

If local codes require external application of insulation blanket kits the manufacturer's instructions included with the kit must be carefully followed.

⚠ WARNING

Application of any external insulation to this water heater will require careful attention to the following:

- Do not cover the temperature and pressure relief valve.
- Do not cover jacket access panels to thermostats and heating elements.
- Do not cover electrical junction box of water heater.
- Do not cover operating or warning labels attached to the water heater nor attempt to relocate them on exterior of insulation blanket.

Installation Check List

A. Water Heater Location

- Close to area of heated water demand.
- Indoors and protected from freezing temperatures.
- Area free of flammable vapors.
- Provisions made to protect area from water damage.
- Sufficient room to service water heater.

B. Water Supply

- Water heater completely filled with water.
- Water heater and piping air vented.
- Water connections tight and free of leaks

C. Relief Valve

- Temperature and Pressure Relief Valve properly installed and discharge line run to open drain
- Discharge line protected from freezing.

D. Wiring

- Power supply voltage agrees with water heater rating plate.
- Branch circuit wire and fusing or circuit breaker of proper size.
- Electrical connections tight and unit properly grounded.

Model No. _____ Serial No. _____ Date of Installation _____ Installed By: _____

Operation

SAFETY PRECAUTIONS

- A. Do not turn off power to water heater if it has been subjected to over heating, fire, flood or physical damage.
- B. Do Not turn on water heater unless it is filled with water.
- C. Do Not turn on water heater if cold water supply shut-off valve is closed.
- D. Do Not store or use gasoline or other flammable vapors and liquids, such as adhesives or paint thinner, in vicinity of this or any other appliance. If such flammables must be used, open doors and windows for ventilation.

NOTE: Flammable vapors may be drawn by air currents from surrounding areas to the water heater.

- E. If there is any difficulty in understanding or following the OP-

ERATION or MAINTENANCE instructions, it is recommended that a qualified person or serviceman perform the work.

CAUTION

Hydrogen gas can be produced in a hot water system served by this water heater that has not been used for a long period of time (generally two weeks or more). **HYDROGEN GAS IS EXTREMELY FLAMMABLE!!** To dissipate such gas and to reduce risk of injury, it is recommended that the hot water faucet be opened for several minutes at the kitchen sink before using any electrical appliance connected to the hot water system. If hydrogen is present, there will probably be an unusual sound such as air escaping through the pipe as the water begins to flow. Do not smoke or use an open flame near the faucet at the time it is open.

1. **WATER TEMPERATURE SETTING** — The temperature of the water in the water heater can be regulated by setting the temperature dial of the adjustable surface mounted thermostat(s) located behind the jacket access panel(s). Dual element heaters have two thermostats. To comply with safety regulations the thermostat(s) are factory set at 120° F or less where local codes require.

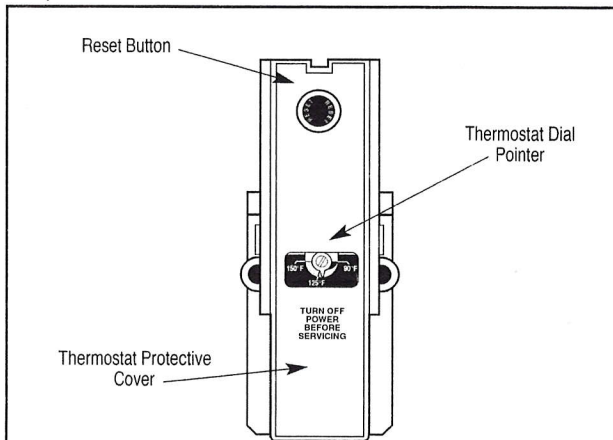

CAUTION!! — Hotter water increases the risk of SCALDING!

This illustration shows the temperature adjustment dial used for setting the water temperature. Refer to Section 1 - Water Temperature Setting, above, for more details and safety instructions regarding water temperature setting.

Figure 4. — Thermostat and Protective Cover.

Safety and energy conservation are factors to be considered when selecting the water temperature setting of the water heater's thermostat(s). The lower the temperature setting the greater the savings in energy and operating costs.

DANGER

There is a Hot Water SCALD Potential if the thermostat is set too high.

NOTE: Households with small children or invalids may require a 120° F or lower thermostat setting to prevent contact with "HOT" water.

TIME / TEMPERATURE RELATIONSHIPS IN SCALDS

Temperature	Time to Produce Serious Burn
120° F	More than 5 minutes
125° F	1 1/2 to 2 minutes
130° F	About 30 seconds
135° F	About 10 Seconds
140° F	Less than 5 seconds
145° F	Less than 3 seconds
150° F	About 1 1/2 seconds
155° F	About 1 second

Table courtesy of Shriners Burn Institute

DANGER

Make certain power to water heater is OFF before removing jacket access panel(s) FOR ANY REASON.

If adjustment is necessary, **turn off** power to water heater, remove jacket access panel(s) and insulation exposing thermostat(s). The thermostat protective cover(s) **should not be removed**. Set thermostat(s) dial pointer(s), with a small screwdriver, to desired temperature. (Refer to Fig. 4.) Replace insulation and jacket access panel(s). Turn on power to water heater.

2. **SAFETY CONTROLS** — The water heater is equipped with a combination Thermostat and Temperature Limiting Control (ECO) that is located above the heating element in contact with the tank surface. If for any reason the water temperature becomes excessively high, the Temperature Limiting Control (ECO) breaks the power circuit to the heating element. Once the control opens, it must be reset manually.

CAUTION

The cause of the High Temperature Condition must be investigated by qualified service personnel and corrective action taken before placing the water heater in service again.

To reset Temperature Limiting Control, **turn off** power to water heater, remove jacket access panel(s) and insulation. **The ther-**

Operation

mostat protective cover **SHOULD NOT** be removed. (Refer to Fig. 4.) Press red "RESET" button. Replace insulation and jacket access panel(s) before turning on power to water heater.

3. EMERGENCY INSTRUCTIONS —

WARNING

If water heater has been subjected to flood, fire, or physical damage, turn off power and water to water heater. Do not operate the water heater again until it has been thoroughly checked by qualified service personnel.

4. **VACATION AND LONG TIME SHUT-DOWN** — If the water heater is to remain idle for an extended period of time, the power and water to the water heater should be turned off to conserve energy. The water heater and piping should be drained if they might be subjected to freezing temperatures.

NOTE: Refer to "Hydrogen Gas Caution" in Safety Precautions Section on page 6.

After a very long shut-down period, the water heater's operation and controls should be checked by qualified service personnel. Make certain the water heater is completely filled before again placing it in operation.

5. DRAINING HEATER —

CAUTION

Shut off power to water heater before draining water.

In order to drain water heater, turn off cold water supply, then it is necessary to open a hot water faucet or lift the handle on the relief valve to admit air to the tank. Attach a garden hose to the drain valve on the water heater and direct the stream of water to a drain where it will do no damage.

DANGER

The water drained from the tank may be hot enough to present a **SCALD HAZARD** and should be directed to a suitable drain to prevent injury or damage.

6. **ANODE** — This water heater is equipped with an anode rod designed to prolong the life of the glass lined tank. The anode is slowly consumed cathodically, thereby eliminating or minimizing corrosion of the glass lined tank.

Water sometimes contains a high sulfate and/or mineral content and together with the cathodic protection process can produce a hydrogen sulfide or rotten egg odor in the heated water. Chlorination of the water supply should minimize the problem.

NOTE: Do not remove the anode rod from the water heater's tank, except for inspection and/or replacement, as permanent removal will shorten the life of the glass lined tank and effect the water heater warranty.

Maintenance

Properly maintained, your water heater will provide years of dependable trouble-free service. It is suggested that a routine preventive maintenance program be established and followed by the user. It is further recommended that a periodic inspection of the operating controls, heating element and wiring should be made by service personnel qualified in electric appliance repair.

1. ROUTINE PREVENTATIVE MAINTENANCE

- A. Most electrical appliances make some sound when in operation, even when new. If the hissing or singing sound level increases excessively, the electric heating element may require cleaning. Contact your installer or plumbing contractor to inspect.
- B. The area near the water heater must be kept free of flammable liquids such as gasoline or paint thinners, adhesives or other combustible materials.
- C. At least once a year, lift and release the lever handle on the temperature pressure relief valve, located near the top of the water heater, to make certain the valve operates freely and allow several gallons to flush through discharge line. Make certain the discharged water is directed to an open drain.

DANGER

Before manually operating the relief valve, make certain no one will be exposed to the danger of coming in contact with the hot water released by this valve. The water may be hot enough to create a **SCALD HAZARD**. The water released should be directed to a suitable drain to prevent injury or damage.

NOTE: If the temperature and pressure relief valve on the water heater discharges periodically, this may be due to thermal expansion in a "Closed" water system. Contact the water supplier or your plumbing contractor on how to correct this. **DO NOT** plug the relief valve outlet.

- D. A water heater's tank can act as a settling basin for solids suspended in the water. It is, therefore, not uncommon for hard water deposits to accumulate in the bottom of the tank. It is suggested that a few quarts of water be drained from the water heater's tank every month to clean the tank of these deposits.
- E. Rapid closing of faucets or solenoid valves in automatic water using appliances can cause a pounding "water hammer" sound. "Water hammer" can be described as a banging noise heard in a water pipe following an abrupt alteration of the flow with resulting pressure surges. Strategically located risers in the water pipe system can be used to minimize the problem. Also water hammer arresting devices are usually available from your plumber or local plumbing supply store.
2. **ANODE ROD INSPECTION** — The anode rod should be removed from the water heater's tank annually for inspection and replaced when more than 6" of core wire is exposed at either end of the rod. Refer to Fig. 2 for anode rod location. Make certain cold water supply is turned off before removing anode rod.

Replacement Parts List

20 - 120 Gallon Models Single and Double Element

Instructions for placing a Parts Order:

Address parts orders to the distributor or store from where the heater was purchased. All parts orders should include:

1. Model number and Serial number of heater (from rating plate).
2. Specify voltage and wattage as marked on rating plate.
3. Part Description (as noted at right) and number of parts desired.

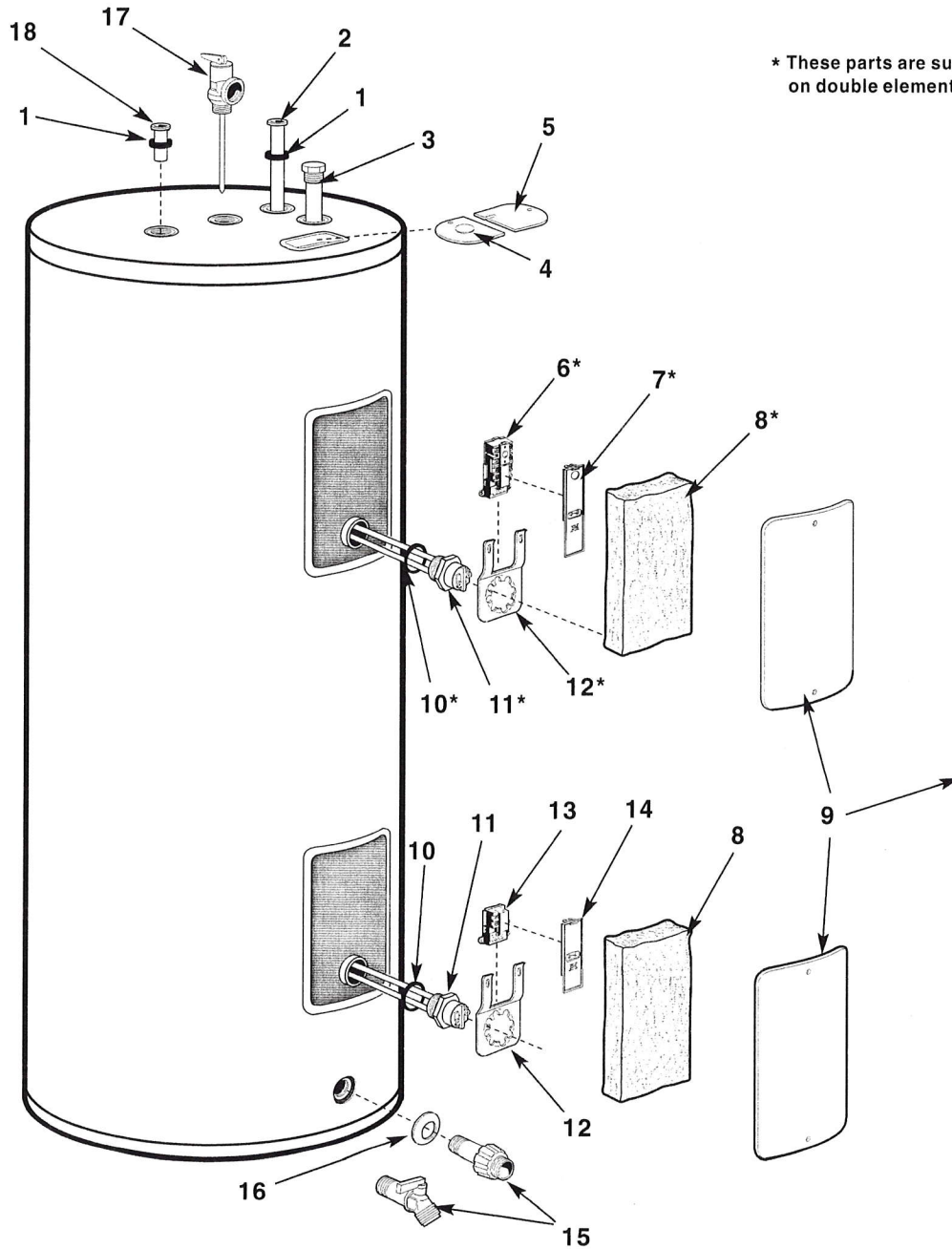

Replacement Parts List

Ref. No.	Part Description	Qty. Req'd
1.	Dip Tube Gasket	2
2.	Dip Tube	1
3.	Anode Rod	1
4.	Plate Cover	1
5.	Junction Box Cover	1
6.	Upper Thermostat (on double element models only)	1
7.	Upper Thermostat Protective Cover (on double element models only)	1
8.	Cavity Insulation	2
9.	Jacket Access Panel	As Req'd
10.	Heating Element Gasket	As Req'd
11.	Heating Element	As Req'd
12.	Thermostat Bracket	As Req'd
13.	Lower Thermostat	1
14.	Lower Thermostat Protective Cover	1
15.	Drain Valve	1
16.	Drain Valve Shroud	1
17.	Relief Valve	1
18.	Hot Outlet Heat Trap or Dip Cup Insert	1
	Owners Manual	1

⚠ CAUTION

For your safety, DO NOT attempt repair of electrical wiring, thermostats, heating elements or other operating controls. Refer repairs to qualified service personnel.

Notes

Trouble Shooting Guide

NATURE OF TROUBLE	POSSIBLE CAUSE	SERVICE
No Hot Water	<ol style="list-style-type: none"> 1. Manual switch turned off 2. Improper Wiring 3. No Power — blown fuse or circuit breaker tripped <ol style="list-style-type: none"> a. Shorted wiring b. Circuit overloaded c. Improper wiring d. Grounded element or thermostat 4. Manual Reset Limit (ECO) open <ol style="list-style-type: none"> a. Thermostat(s) defective b. Thermostat out of calibration c. Heat build-up due to loose wires d. Defective Limit (ECO) 	Turn to ON ** Rewire per Wiring Diagram ** Replace or repair ** Provide adequate circuit or reduce load ** Rewire per diagram ** Replace Refer to "Operation Section" ** Replace ** Lower setting or replace ** Tighten wire connections ** Replace
Not enough Hot Water	<ol style="list-style-type: none"> 1. Heater undersized 2. Defective Element(s) 3. Miswired or defective thermostat causing only one element to work 	Reduce rate of hot water use ** Check amperage, replace element if low ** Check wiring or replace
Water too hot or not hot enough	<ol style="list-style-type: none"> 1. Thermostat setting too high or low 2. Thermostat out of calibration 	Change setting as required ** Replace
Noisy heating element(s)	<ol style="list-style-type: none"> 1. Scale build-up on elements 	** Remove and clean
Rattling noise during periods of water usage	<ol style="list-style-type: none"> 1. Internal Heat Trap fittings in operation 	None. The rattling noise is normal for Heat Trap fittings when in operation and does not indicate a need for service.

⚠ CAUTION

** For your safety, DO NOT attempt repair of Electrical Wiring, Thermostat(s), Heating Elements or other Operating Controls. Refer repairs to qualified service personnel.

How to Obtain Service Assistance

1. Should you have any questions about your new water heater, or if it requires adjustment, repair, or routine maintenance, it is suggested that you first contact your installer, plumbing contractor or previously agreed upon service agency. In the event that the firm has moved, or is unavailable, refer to the telephone directory commercial listings or local utility for qualified service assistance.
2. Should your problem not be solved to your complete satisfaction, you should then contact the Manufacturer's National Service Department at the following address:
 2600 Gunter Park Drive
 Montgomery, Alabama 36109-1413
 Phone: 1-800-432-8373.

When contacting the manufacturer, the following information should be made available:

1. Model and serial numbers of the water heater as shown on the rating plate attached to the jacket of the heater.
2. Address where water heater is located and can be seen.
3. Name and address of installer and any service agency who performed service on the water heater.
4. Date of original installation and dates any service work was performed.
5. Details of the problem as you can best describe them.
6. List of people, with dates, who have been contacted regarding your problem.



NOTICE



FOR INSTALLATIONS IN THE STATE OF CALIFORNIA

California Law requires that residential water heaters must be braced, anchored or strapped to resist falling or horizontal displacement due to earthquake motions. For residential water heaters up to 52 gallon capacity, a brochure with generic earthquake bracing instructions can be obtained from:

OFFICE OF THE STATE ARCHITECT
400 P Street
Sacramento, CA 95814
Telephone: (916)324-5315

or, ask a water heater dealer. However, applicable Local Codes shall govern installations. (For residential water heaters of capacity greater than 52 gallons, consult the local building jurisdiction for acceptable bracing installations)

----- Supplemental Instructions -----

The installation instructions in the Use & Care Manual supplied with the water heater should be followed in addition to the following Supplemental Instructions.

For increased energy efficiency, certain water heater models covered by this Use & Care Manual have been supplied with two (2) 24" sections of pipe insulation. Should the model being employed in your particular installation include the pipe insulation, please install the insulation as shown below for the type of installation configuration that best matches yours.

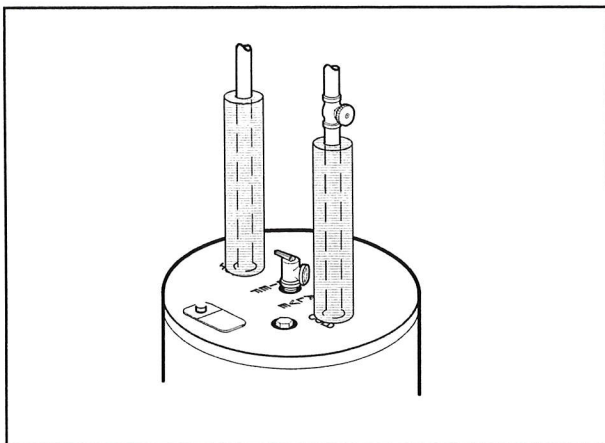

Figure 1. Typical Vertical piping arrangement.
(Your installation may vary slightly.)

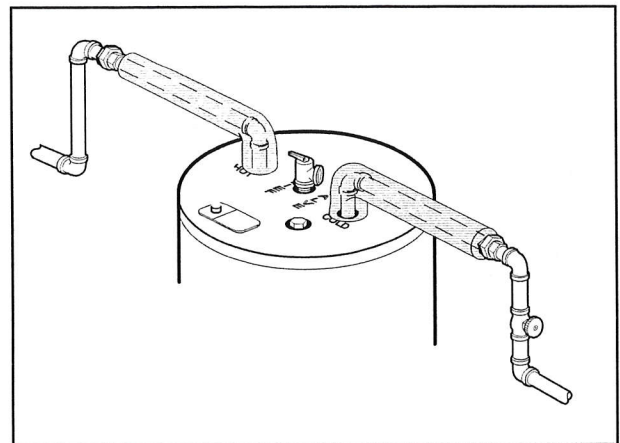

Figure 2. Typical Horizontal piping arrangement.
(Your installation may vary slightly.)

Wiring Diagrams — Therm-O-Disc Thermostats (Type 59T)

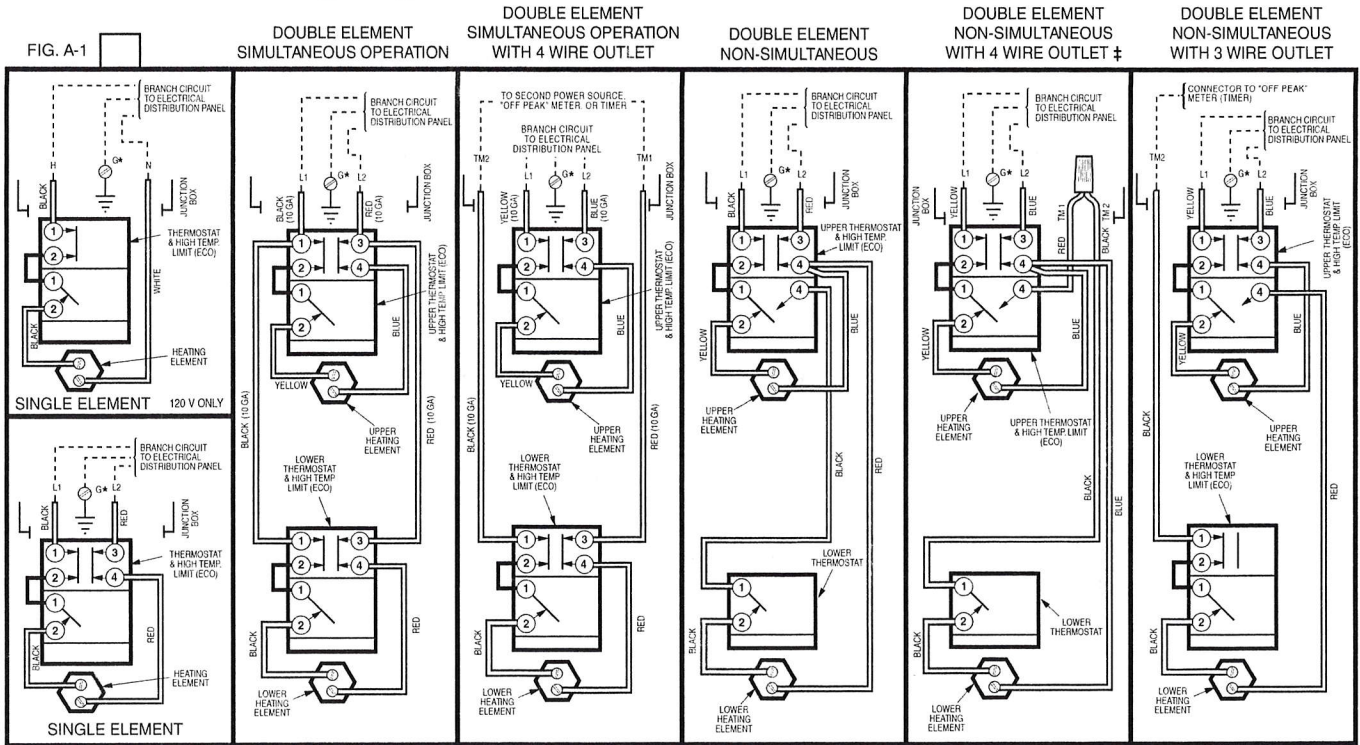

FIG. A-1 FIG. B FIG. C FIG. D FIG. E FIG. F

* Grounding conductor may be required. Refer to Wiring Section of Manual

‡ This water heater is factory equipped for two (2) wire connection to electrical power. For use with "off-peak" meter (timer) remove nut from red and black leads and connect to "off-peak" meter (timer).

THIS ELECTRIC WATER HEATER IS WIRED AS INDICATED ABOVE OR BELOW

Wiring Diagrams Electric Water Heaters for 3 - Phase Applications Therm-O-Disc Thermostats (Type 59T)

For the connection of this water heater to a 3-Phase Branch Circuit, connect field wiring to the water heater as indicated in the appropriate wiring diagram at right. A separate junction box is being supplied with this water heater (check bottom of carton) to accommodate wiring and conduit connections. Install the Junction Box as shown on the Installation/Instruction Sheet included in the plastic bag attached to the heater.

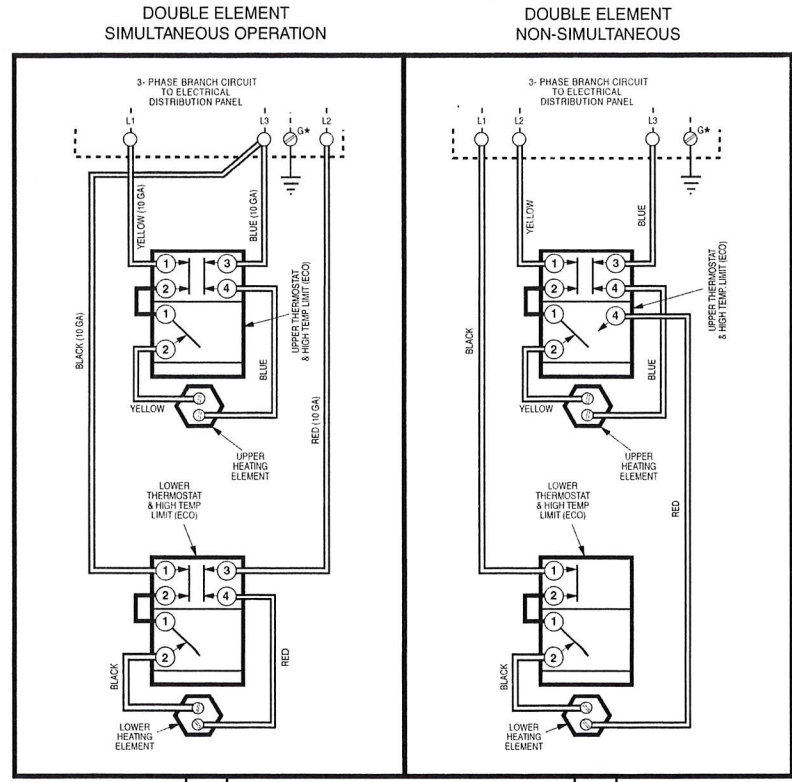

FIG. G FIG. H

Delta Warranty

With Delta® Faucet Company, you can be sure you're getting products of the highest quality. That's why we offer a limited lifetime guarantee on almost every product line. Take a look at our warranty plan for more details.

Lifetime Faucet and Finish Limited Warranty

All parts and finishes of the Delta faucet are warranted to the original consumer purchaser to be free from defects in material and workmanship for as long as the original consumer purchaser owns their home. Delta recommends using a professional plumber for all installation and repair.

Delta will replace, FREE OF CHARGE, during the warranty period, any part or finish that proves defective in material and/or workmanship under normal installation, use and service.

Replacement parts may be obtained by calling 1-800-345-DELTA (3358) or by writing:

Delta Faucet Company
Product Service
55 E. 111th Street
Indianapolis, IN 46280

This warranty is extensive in that it covers replacement of all defective parts and even finish, but these are the only two things that are covered. LABOR CHARGES AND/OR DAMAGE INCURRED IN INSTALLATION, REPAIR, OR REPLACEMENT, AS WELL AS ANY OTHER KIND OF LOSS OR DAMAGE ARE EXCLUDED. Proof of purchase (original sales receipt) from the original consumer purchaser must be made available to Delta for all warranty claims. THIS IS THE EXCLUSIVE WARRANTY BY DELTA FAUCET COMPANY, WHICH DOES NOT MAKE ANY OTHER WARRANTY OF ANY KIND, INCLUDING THE IMPLIED WARRANTY OF MERCHANTABILITY.

This warranty excludes all industrial, commercial and business usage, of faucets whose purchasers are hereby extended a five-year limited warranty from the date of purchase, with all other terms of this warranty applying except the duration of the warranty. This warranty is applicable only to Delta faucets manufactured after January 1, 1995.

Some states do not allow the exclusion or limitation of incidental or consequential damages, so the above limitation or exclusion may not apply to you. Any damages to this faucet as a result of misuse, abuse, or neglect or any use of other than genuine Delta replacement parts WILL VOID THE WARRANTY.

This warranty gives you specific legal rights, and you may also have other rights which vary from state to state. It applies only to Delta faucets installed in the United States of America, Canada and Mexico.

If you have any questions or concerns regarding our warranty plan, please [e-mail](#) us, or call 1-800-345-DELTA (3358).

